



UM08010-R4 User Manual

J-Link JTAG Isolator

Introduction

The J-Link JTAG Isolator can be connected between J-Link ARM and any ARM-board that uses the standard 20-pin JTAG-ARM connector to provide electrical isolation. This is essential when the development tools are not connected to the same ground as the application. It is also useful to protect the development tools from electrical spikes that often occur in some applications, such as motor control applications.

A 20-pin flat cable (supplied with J-Link) is needed to connect the target.

Power supply

Both sides, target and emulator, are totally isolated and separately powered. The target side draws power from pins 1 or 2, the emulator side draws power from pin 19.

Figure 1. J-Link JTAG Isolator

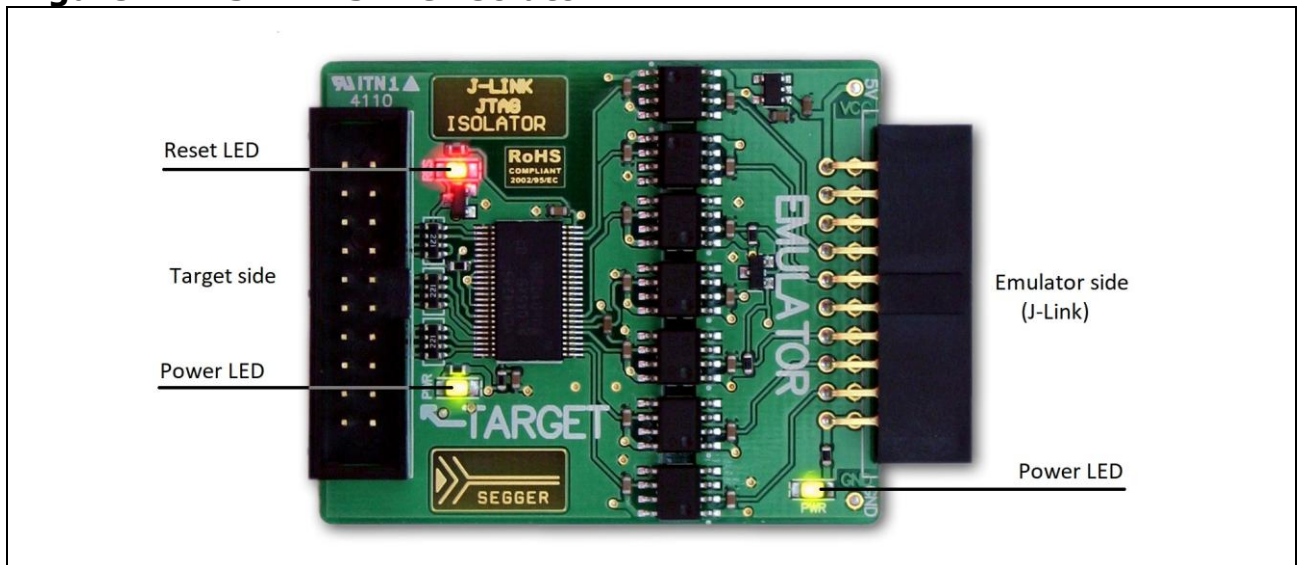

Features

- Basic isolation (1 kV DC)
- 3.3V and 5V target operation supported
- Powered from emulator and target
- JTAG standard 20-pin connection supporting TRST, TDI, TMS, TCK, RTCK, TDO and RESET signals
- Power consumption on target side: 35mA typ. / 50mA max.
- JTAG frequency: Up to 4MHz
- 3 LEDs to indicate emulator power, target power and target RESET

Connectors and indicators

The JTAG Isolator uses high speed optocouplers that allow a very low propagation time between input and output. It comes with the following connectors and indicators:

- 20-pin female EMULATOR connector which can be plugged directly into J-Link
- 20-pin male TARGET connector for connection of the target cable
- Green LED indicating power on the emulator side
- Green LED indicating power on the target side
- Red LED indicating RESET

Block diagram

The functional block diagram (Figure 2) illustrates the functional connections between the emulator and target.

Figure 2. Functional block diagram

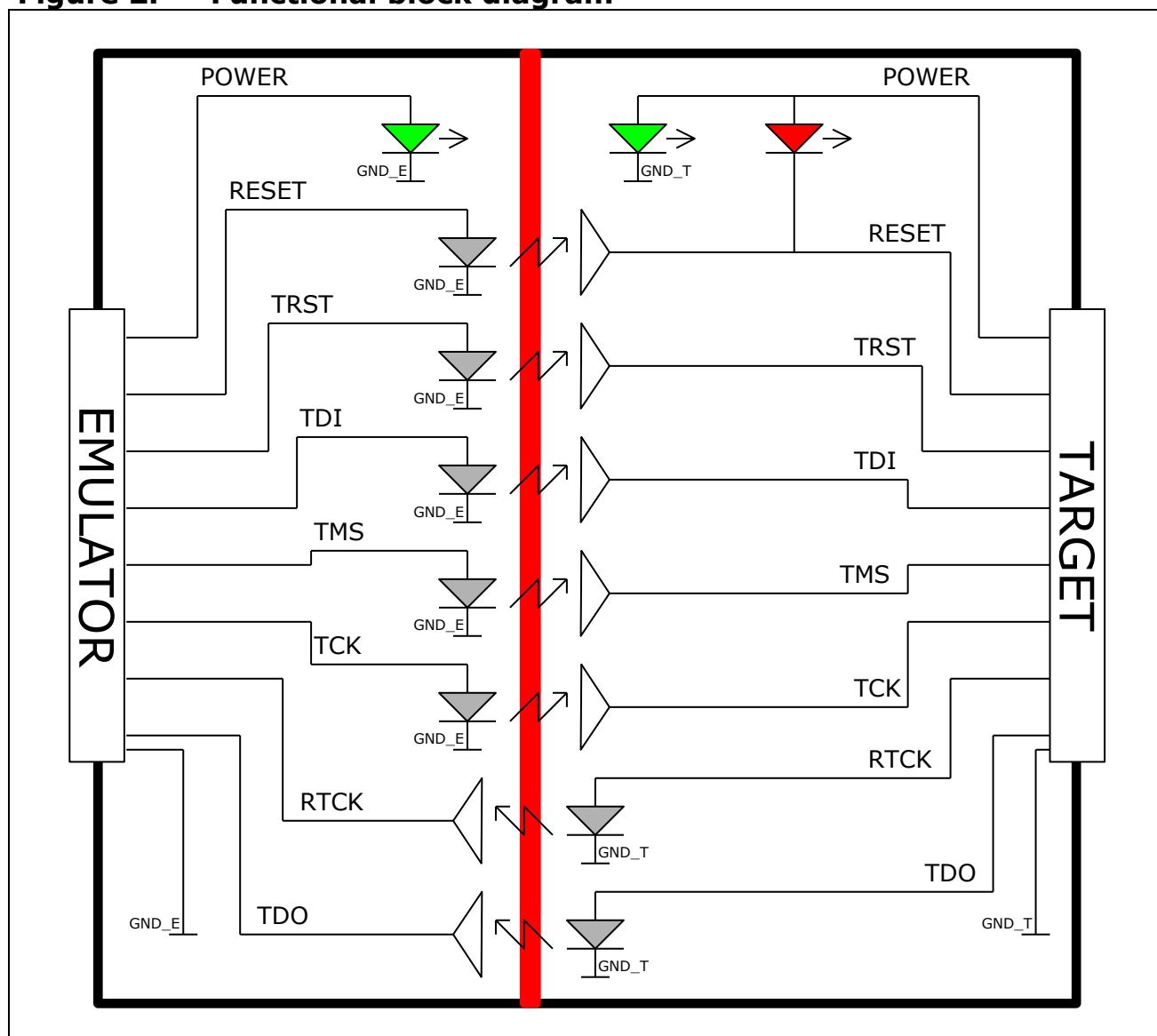

Connecting the Isolator to Target and Emulator

Figure 3. Connecting the Isolator to Target and Emulator

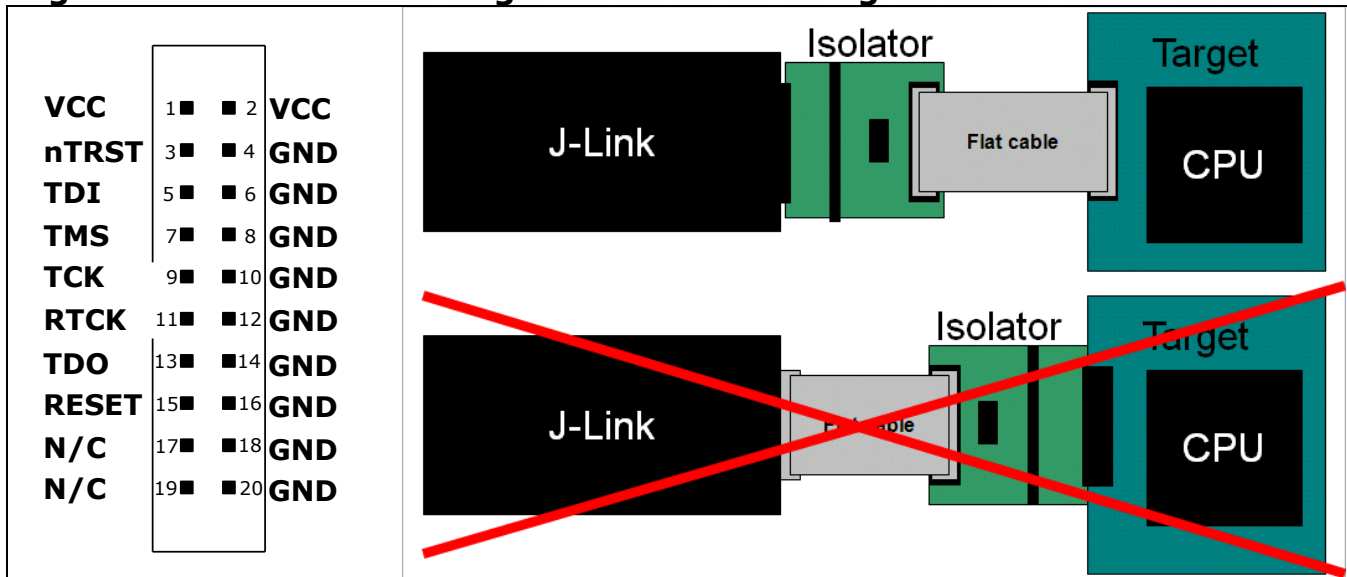

The Emulator side of the Isolator is plugged directly into the Emulator. The Target side is connected to the target via a 20-pin flat cable.

Using the Isolator with J-Link

In order to use the Isolator, follow these steps:

- Plug the Isolator directly into J-Link.
- Power J-Link.
- Make sure the green LED on the emulator side is lit. If it is not, follow the instruction in the next section.
- Connect the target via 20-pin flat cable to the target side of the Isolator.
- If the target is powered, the green LED on the target side should be lit.

The red LED on the target side is lit when a Target RESET is active (low).

Preparing J-Link to supply power

J-Link needs to supply 5V power to the emulator side of the adapter on pin 19. In order to do this, you may have to configure J-Link once as follows:

- Make sure that SEGGER J-Link software is installed on your machine. It can be downloaded from <http://www.segger.com/downloads/jlink/>
- Start J-Link Commander, which can be found under "Start -> Programs -> SEGGER -> J-Link"
- Enter the following command: power on perm
- Plug in the adapter: The LED on the emulator side should now be lit.

Using the Isolator with another ARM emulator

The Isolator has been designed for J-Link, but can also be used with other ARM emulators with the same pin-out. In this case, you should make sure that 5V are supplied to pin 19 of the emulator connector and that your emulator is not damaged when applying 5V to this pin. **Do this at your own risk!**

Disclaimer

Specifications written in this document are believed to be accurate, but are not guaranteed to be entirely free of error. The information in this manual is subject to change for functional or performance improvements without notice. Please make sure your manual is the latest edition. While the information herein is assumed to be accurate, SEGGER Microcontroller GmbH (the manufacturer) assumes no responsibility for any errors or omissions. The manufacturer makes and you receive no warranties or conditions, express, implied, statutory or in any communication with you. The manufacturer specifically disclaims any implied warranty of merchantability or fitness for a particular purpose.

Copyright notice

You may not extract portions of this manual or modify the PDF file in any way without the prior written permission of the manufacturer.

© 2020 SEGGER Microcontroller GmbH, Monheim am Rhein / Germany

Trademarks

Names mentioned in this manual may be trademarks of their respective companies.

Brand and product names are trademarks or registered trademarks of their respective holders.

Contact address

SEGGER Microcontroller GmbH
Ecolab-Allee 5
D-40789 Monheim am Rhein
Germany
Tel.+49 2173-99312-0
Fax.+49 2103-99312-28
Email: support@segger.com
Internet: <http://www.segger.com>

Revisions

Revision	Date	By	Explanation
0	080104	OO	Initial version
1	080109	OO	Added / updated picture for better understanding.
2	080118	OO	Updated Figure 2 "Functional block diagram"
3	080827	OO	Minor changes
4	201013	MK	Updated pictures and contact address