



# UM08010-R5 User Manual

## JTAG Isolator

### Introduction

The JTAG Isolator can be connected between J-Link and any target to provide electrical isolation. This is essential when the development tools are not connected to the same ground as the application. It is also useful to protect the development tools from electrical spikes that often occur in some applications, such as motor control. Another typical field of application is the development of products with sensors or other analog circuitry, in which case the target hardware is protected from electrical noise originating from the development PC.

### Power supply

Both sides, target and emulator, are fully isolated. The JTAG Isolator is powered fully from pin 19 of the emulator side connector.

**Figure 1. JTAG Isolator**



### Features

- Basic isolation (1 kV DC)
- 1.2V to 5V target operation supported
- Fully powered from the emulator side
- JTAG standard 20-pin 0.1" connector on target and probe side supporting TRST, TDI, TMS, TCK, RTCK, TDO and RESET signals
- Power consumption on target side: < 35µA
- JTAG frequency: Up to 4MHz
- 4 LEDs to indicate emulator power/overload, target power and target RESET

## Connectors and indicators

The JTAG Isolator uses isolating high-speed DC-DC converters that feature a very low propagation time between input and output. It comes with the following connectors and indicators:

- 20-pin 0.1" male connector for connecting to an emulator
- 20-pin 0.1" male connector for connecting to a target
- Power/Overload LED (Emulator side):
  - Green: Indicates power on the emulator side
  - Red: Indicates power overload on the emulator side
- Connect/Reset LED (Target side):
  - Green: Indicates power on the target side
  - Red: Indicates the target is in reset or powered off

## Block diagram

The functional block diagram (Figure 2) illustrates the functional connections between the emulator and target.

**Figure 2. Functional block diagram**

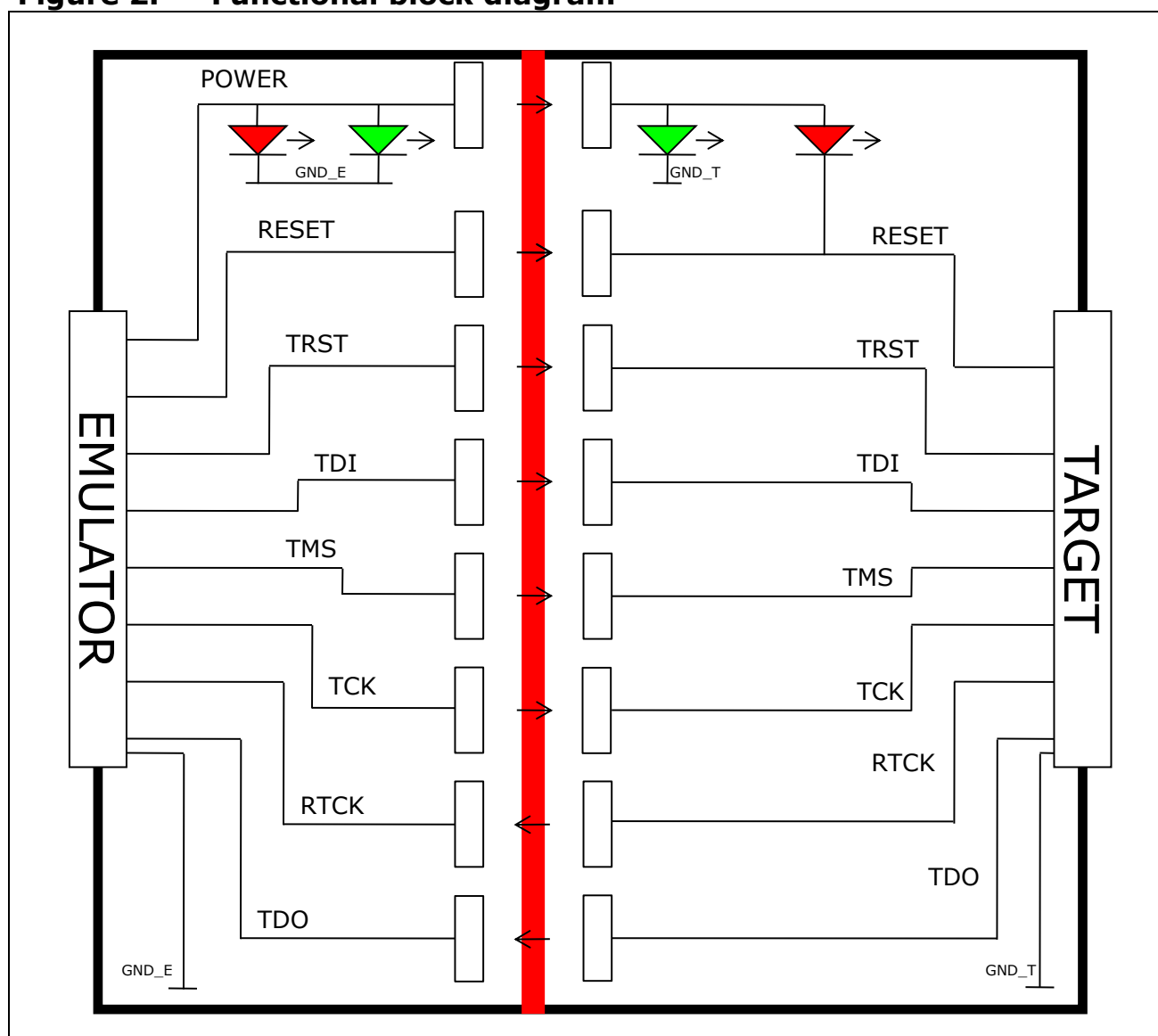

## Using the Isolator with J-Link

In order to use the Isolator, follow these steps:

- Connect the JTAG Isolator via a 20-pin 0.1" flat cable to the J-Link.
- Power J-Link.
- Make sure the green LED (Power) on the emulator side is lit. If it is not, follow the instructions in the next section.
- Connect the target to the target side of the JTAG Isolator.
- If the target is powered, the green LED (Connect) on the target side should be lit.

The red LED (Reset) on the target side is lit when a Target RESET is active (low).

## Preparing J-Link to supply power

J-Link needs to supply 5V power to the emulator side of the adapter on pin 19. In order to do this, you may have to configure J-Link once as follows:

- Make sure that SEGGER J-Link software is installed on your machine. It can be downloaded from <https://www.segger.com/downloads/jlink/>
- Start J-Link Commander, which can be found under "Start -> Programs -> SEGGER -> J-Link"
- Enter the following command: power on perm
- Plug in the isolator: The green LED (Power) on the emulator side should now be lit.

## Using the Isolator with another ARM emulator

The Isolator has been designed for J-Link but can also be used with other ARM emulators with the same pin-out. In this case, you should make sure that 5V are supplied to pin 19 of the emulator connector and that your emulator is not damaged when applying 5V to this pin. **Do this at your own risk!**

## Disclaimer

Specifications written in this document are believed to be accurate, but are not guaranteed to be entirely free of error. The information in this manual is subject to change for functional or performance improvements without notice. Please make sure your manual is the latest edition. While the information herein is assumed to be accurate, SEGGER Microcontroller GmbH (the manufacturer) assumes no responsibility for any errors or omissions. The manufacturer makes and you receive no warranties or conditions, express, implied, statutory or in any communication with you. The manufacturer specifically disclaims any implied warranty of merchantability or fitness for a particular purpose.

## Copyright notice

You may not extract portions of this manual or modify the PDF file in any way without the prior written permission of the manufacturer.

© 2026 SEGGER Microcontroller GmbH, Monheim am Rhein / Germany

## Trademarks

Names mentioned in this manual may be trademarks of their respective companies.

Brand and product names are trademarks or registered trademarks of their respective holders.

## Contact address

SEGGER Microcontroller GmbH  
Ecolab-Allee 5  
D-40789 Monheim am Rhein  
Germany  
Tel.+49 2173-99312-0  
Fax.+49 2103-99312-28  
Email: support@segger.com  
Internet: <https://www.segger.com>

## Revisions

Revision	Date	By	Explanation
0	080104	OO	Initial version
1	080109	OO	Added / updated picture for better understanding.
2	080118	OO	Updated Figure 2 "Functional block diagram"
3	080827	OO	Minor changes
4	201013	MK	Updated pictures and contact address
5	260622	FRO	Updated for hardware revision V2