

History / Changes

- V2.0 Rev.A** First public version
- V2.0 Rev.B** - Replaced PRTR5V0U4Y by NUP4114UCW1T2G
- V2.0 Rev.C** - Used STM32F072C8U6 as OB chip (128k Flash instead of 64k)
 - Connected J400.11/13 to GND to improve shielding on trace cable for TRACEDATA0 and RESET
 - Specified Samtec part number for J400
- V2.0 Rev.D** - Replaced F032 OB by K22 type
 - Replaced Mini USB by Micro USB connector
 - Added 2 GND hooks and testpoints for the LEDs
 - Connected VREG_IN0 and VREG_IN1
 - Connected J400.11/13 via capacitor to GND to allow for optional power supply here
 - Replaced oscillator type EAA501 (obsolete)
 - Replaced diodes BAR43C (obsolete)

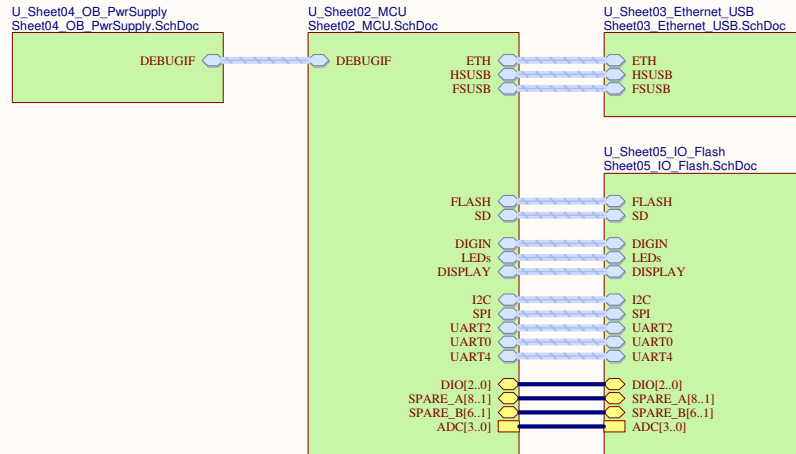

Unless otherwise specified:

- =====
- Ceramic capacitors are of type X5R/X7R or C0G/NP0 with a voltage rating of at least 6.3V
 - Resistors are 1% tolerance types

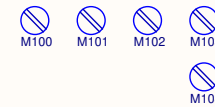

History / Changes (see left)		 J-Link™ Technology www.segger.com
Title emPower V2.0 - Top Level		
Size A3	Number -	Revision Rev. D
Date: 190121	Sheet 1 / 5	
File: Sheet01_TopLevel.SchDoc	Drawn: VK	

- * NOTES:**
- MCU GPIO pull up configuration: #SW_A ... #SW_E, #PB, SD_#CD, FS_#PWRFLT
 - MCU does not provide a NAND Flash controller, GPIOs are used instead
 - PTB18 (D_BLON), PTE7-9 (DIOx) are PWM capable timer outputs

A

B

C

D

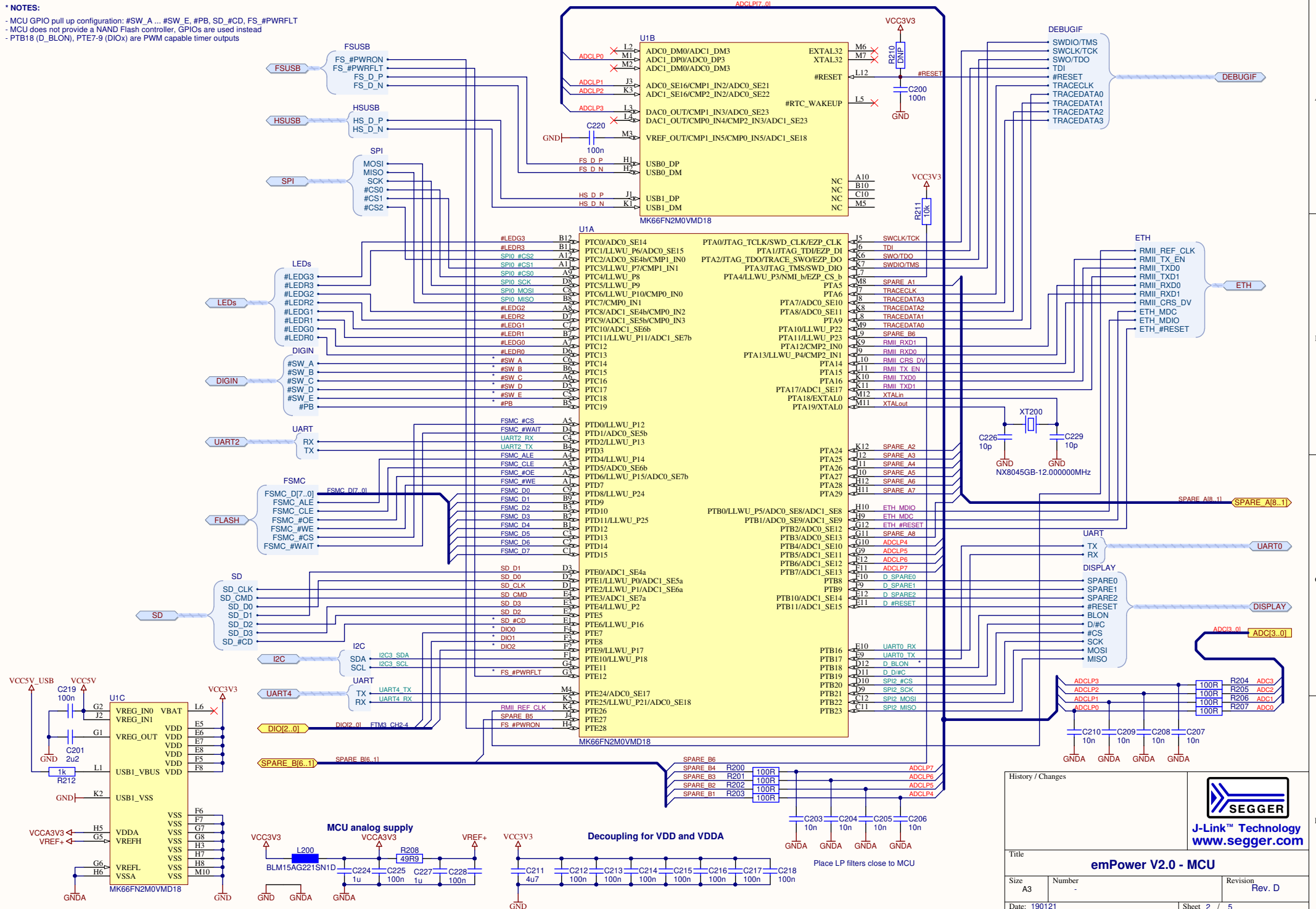

History / Changes



J-Link™ Technology
www.segger.com

Title: **emPower V2.0 - MCU**

Size	Number	Revision
A3	-	Rev. D

Date: 190121
File: Sheet02_MCU.SchDoc

Sheet 2 / 5
Drawn: VK

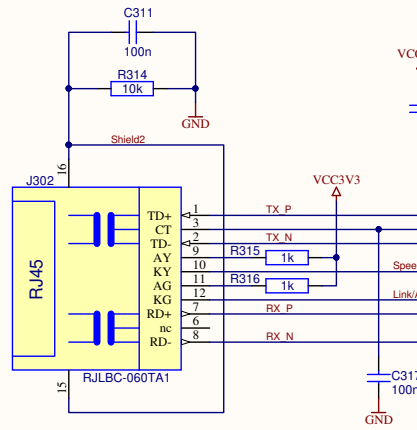
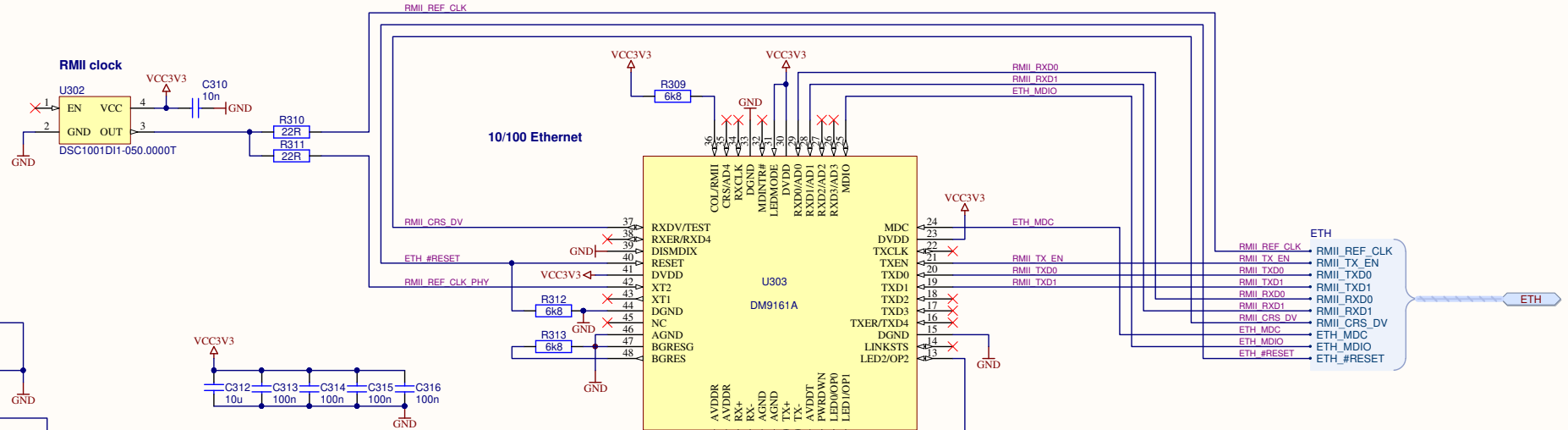
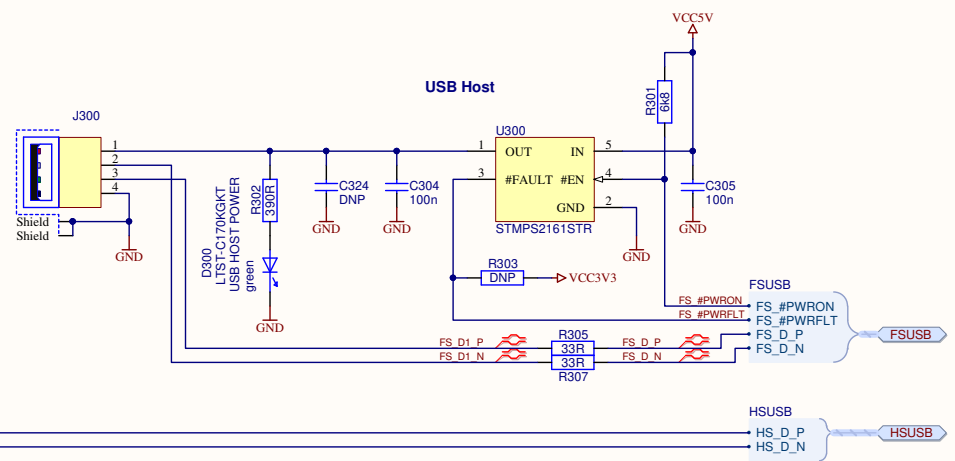
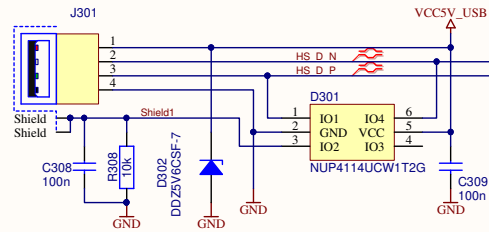

History / Changes



J-Link™ Technology
www.segger.com

Title: **emPower V2.0 - ETH, HS USB, USB Host**

Size	A3	Number	-	Revision	Rev. D
Date:	190121		Sheet:		3 / 5
File:	Sheet03_Ethernet_USB.SchDoc		Drawn:		VK

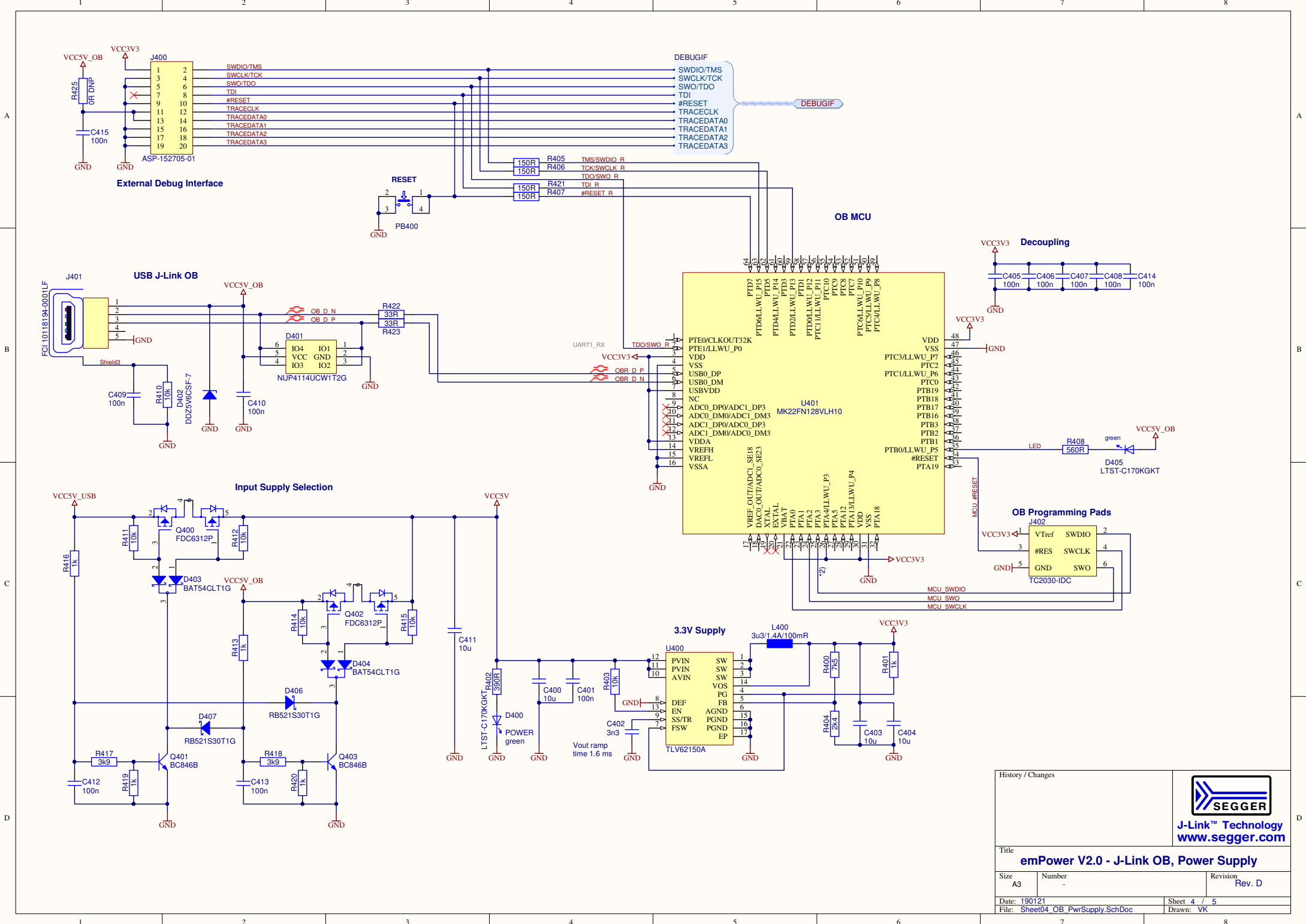

History / Changes		 J-Link™ Technology www.segger.com	
Title			
Size	Number	Revision	Rev. D
A3	-		
Date: 190121	Sheet 4 / 5		
File: Sheet04_OB_PwrSupply_SchDoc	Drawn: VK		

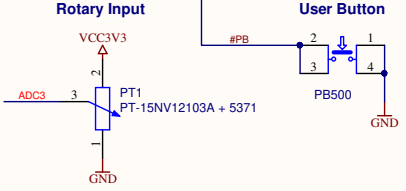
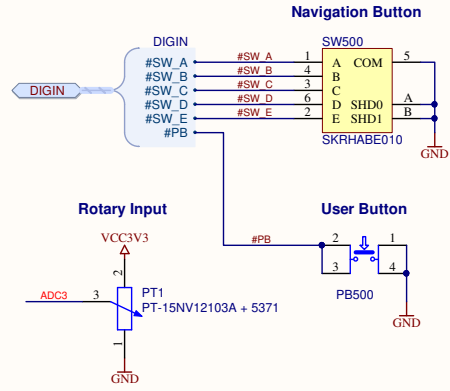
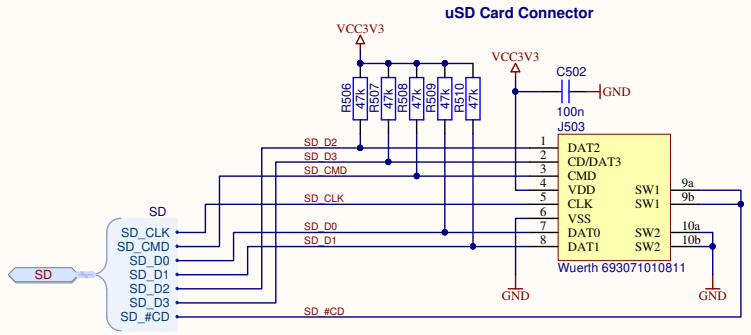
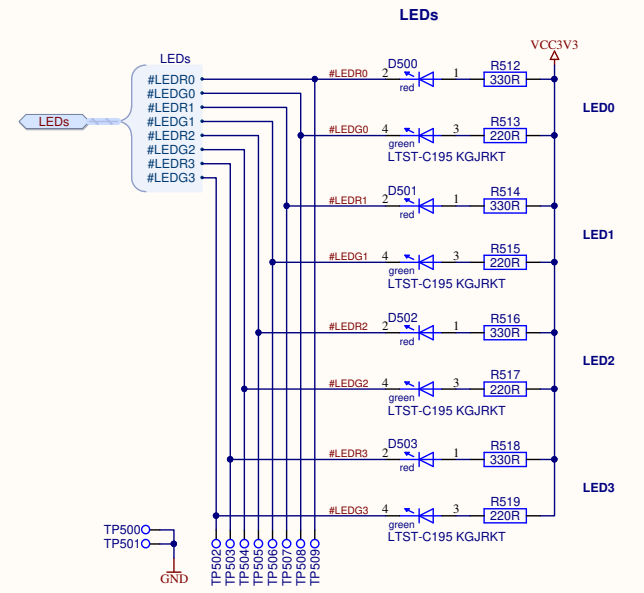
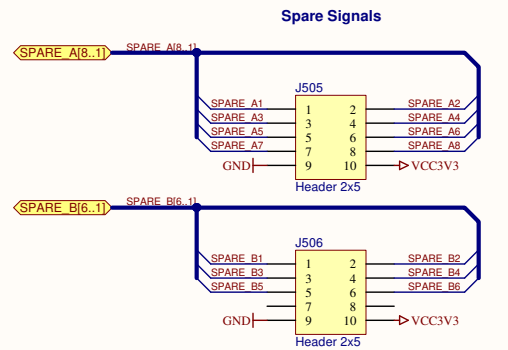
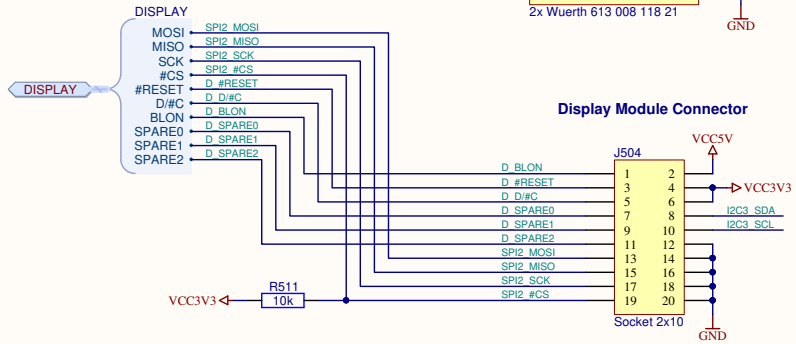
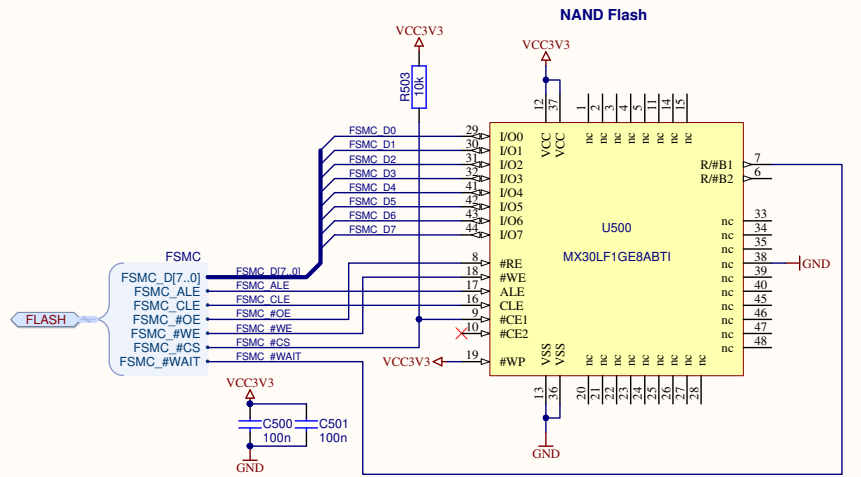
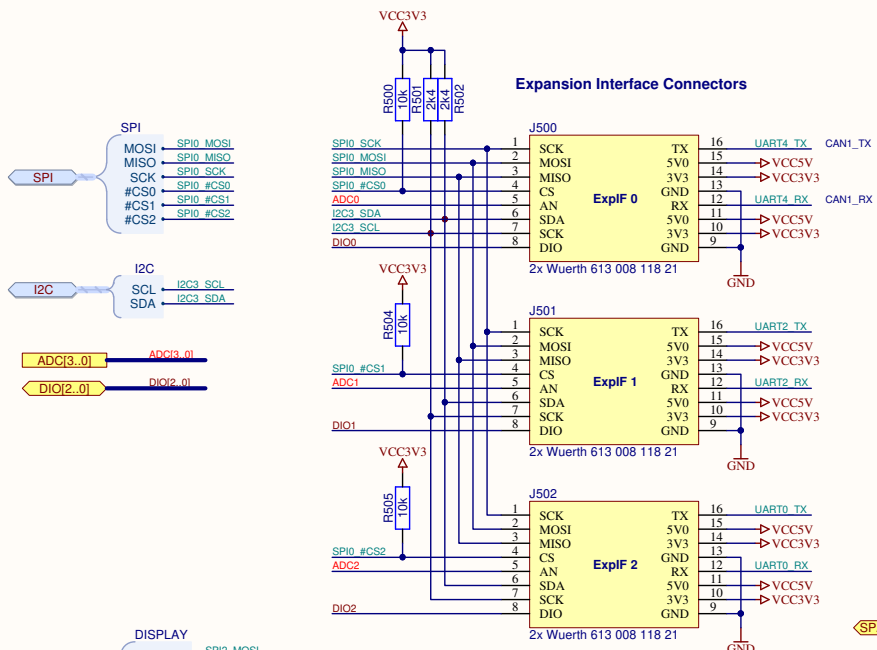

History / Changes			 J-Link™ Technology www.segger.com
Title			
emPower V2.0 - IO, NAND Flash			
Size	Number	Revision	Rev. D
A3	-		
Date: 190121	Sheet 5 / 5		
File: Sheet05_IO_Flash.SchDoc	Drawn: VK		